

MOSTER 185 Plus

Installation manual

release V2/2022

valid for MY19-MY20-MY22 versions

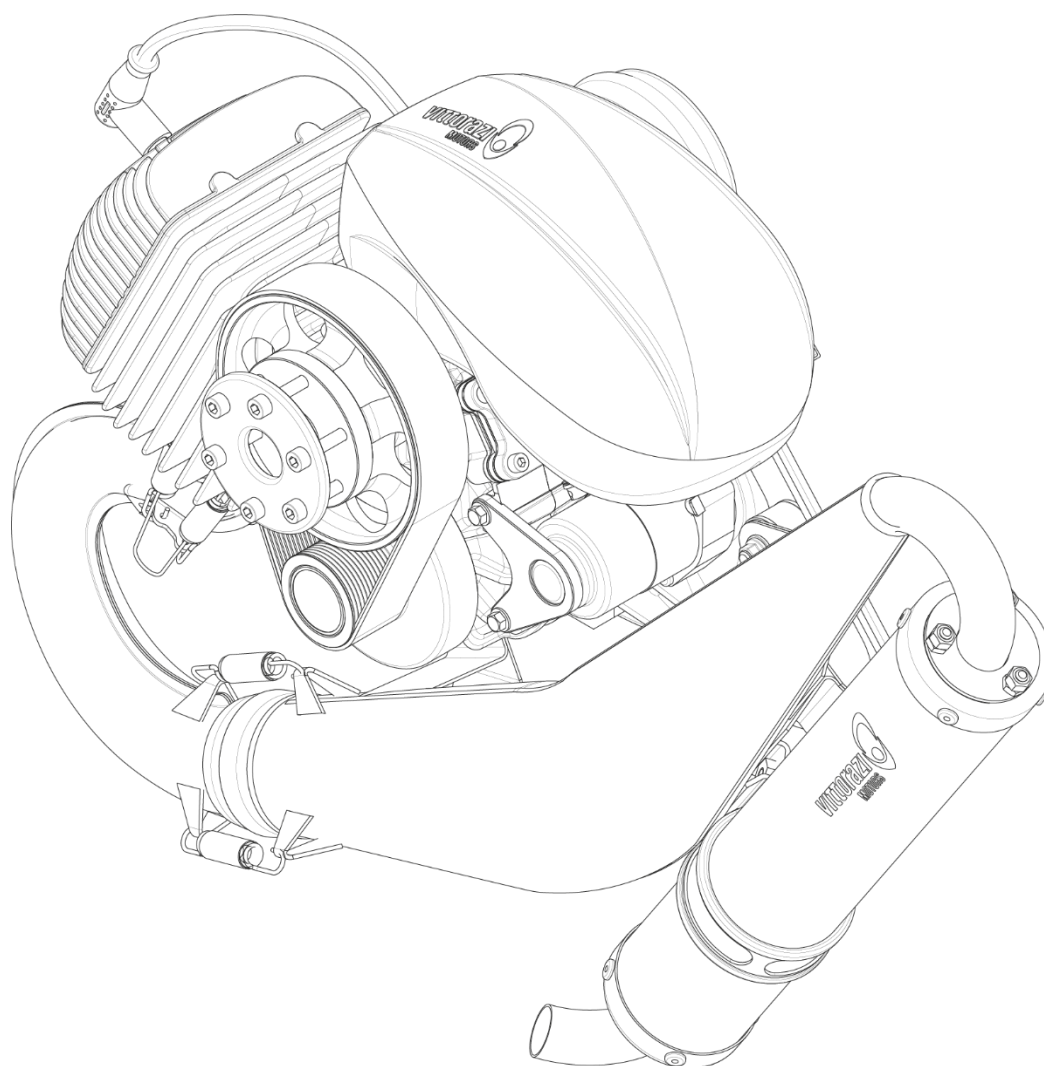

Contents

1	Introduction	4
2	Be careful! Read it completely	6
3	Installation	6
	3.1 Preparing for installation	8
	3.2 Supports to the frame	16
	3.3 Electrical system	17
	3.4 Fuel system	27
	3.5 Bowden carburettor cable	30
	3.6 Manual starter	32
	3.7 Propeller	35
	3.8 Instruments and accessories	36
	3.9 Final checks	37

1 Introduction

Congratulations and thanks for being a Vittorazi qualified professional.

This manual is intended as a point of reference for aircraft manufactures, dealers, professional people dealing with Vittorazi Motors. Please study this professional manual carefully before starting the installation activity. The purpose of this manual is to provide all the necessary information to the professional in order to allow a proper installation of the engine, carried out autonomously and in total security. The professional manual includes: technical descriptions of the installation phase and reference values.

All the components of Vittorazi Motors are checked and tested in a process of industrial quality control before the assembling. Then by sampling the complete motors are checked to assure the functionality of all the parts through a complete test of twenty minutes on the bench. Note that the reliability, performance and durability of the engine also strongly depend on the correct installation of which you are in charge.

In case you need further explanations, you can contact directly the headquarters of Vittorazi Motors. Please include in the request, the six-digit serial number that identifies the motor (read 3.1 "Preparing for installation") and a photo of the item in question.

Also take into account the availability of Illustrated Parts Catalogue (IPC), manual updates, service bulletins, FAQs, other documents in our official website. The video tutorials are available on the Vittorazi Motors official YouTube channel. Below the links.

IPC, manuals, bulletins, newsletter, warranties, FAQ

<https://www.vittorazi.com/en/services/>



Vittorazi Official YouTube channel: video and free tutorials available

<https://www.youtube.com/user/VITTORAZIMOTORS>



Reading tips:

Attention, danger, risk
Any situation or condition which may result in a serious danger



Recommendation, warning, important advice



2 Be careful! Read it completely



To fly in total safety, you must read the following recommendations:

- This engine is not certified. This engine does not fulfil airworthiness regulations. The products are dedicated to non-certified aircraft and flying as a recreational or sporting activity.
- Final-user must be aware that the engine can stop, break or shut down at any time. Such an event may require an immediate and forced landing in inadequate, congested or impervious areas, with the possibility in the end of causing the death of the pilot or other persons involved.
- The aircraft equipped with this engine must be conducted in full compliance with rules and regulations in force relating to the activity of leisure and sport aviation, with regard to the country in which the operations are carried out.
- Vittorazi Motors and its distributors decline any direct or indirect responsibility related to this kind of activity. By using a new engine, the owner agrees that these terms and conditions have been accepted at the time of purchase of the product.
- The engine is not covered by any liability insurance. The use of the engine automatically determines the assumption of all risks and personal liability for personal injury or damage to third parties resulting from the activity.
- Improper use of the products or improper technical service (in relation to the specifications contained in the user, installation and maintenance manual) will hold harmless the company from any liability for any damage due to the malfunctioning and immediately void the warranty of the product. So, do not use the motor if it has not been properly maintained or if it has not been used correctly over time.
- Vittorazi does not assume any responsibility for those engines that are used with parts that are not original, not approved, modified or that have suffered an improper use. Use of spare parts not original and not recognized by Vittorazi, can make the engine dangerous and will void the warranty.
- Unauthorized modifications to the motor, to the reduction, to the propeller can invalidate the warranty of the motor and can compromise the reliability of the aircraft and its safety. In case it is necessary to intervene, we invite you to contact an authorized dealer Vittorazi.
- Some geographical areas, due to particular weather conditions such as pressure, temperature and humidity can affect the performance of the engine. Before taking off, test the engine on the ground and make sure it does not behave abnormally.

- Always start the engine on a flat and clean surface, without stones or sand. During all phases in which the engine is kept running near the ground (such as heating, take off, landing) it is necessary to maintain a safe distance from the engine. A good safety distance is 100 meters in every direction.



The following engine speed limits must be respected to avoid engine failures, to keep the warranty valid and to have a correct maintenance scheduling according to the Vittorazi program:

- Do not keep the engine at full revs for more than 60 seconds.
- Do not keep revs higher than 7.000 RPM during long cruising flights or long climbs. The average power delivered by the engine during a flight should remain below the indicated threshold. Contact the aircraft manufacturer for further clarification.



The temperature limit of CHT is 250° Celsius. Do not persist above this temperature threshold, engine overheating and irreversible damage could occur.



The temperature limit of EGT is 650° Celsius. Do not persist above this temperature threshold, engine overheating and irreversible damage could occur.

3 Installation

This section refers to mechanical and electrical installation, so it is reserved for the aircraft manufacturer (paramotor, hang glider, ultralight and others) who has qualified personnel in the mechanical, electrical and aeronautical fields. By following the instructions, it will be possible to assemble the engine correctly.

Please refer further to the aircraft manual for operation, installation, maintenance. A correct and safe operation of the same engine, cannot be guaranteed in other applications, than those approved by the aircraft manufacturer.

Any procedure of installation, maintenance and/or repair of the products must be carried out exclusively with the original Vittorazi parts and tools specified by Vittorazi, in compliance with the specifications contained in the user, installation and/or maintenance manual of the products; to ensure maximum safety and performance of the products, the above-mentioned procedures will be carried out by mechanics with proven experience in the Ultralight aviation or general aviation or with experience gained by Vittorazi professional training courses. Failure to do so, will held harmless the company from any liability for any damage due to the malfunctioning and immediately void the warranty of the product.

Vittorazi shall not be liable for any damages deriving from the installation of its motors onto aircraft and/or equipment that require airworthiness certifications.

Frame design must give strong consideration to the following sections: 3.2 Supports to the frame, 3.3 Electrical system, 3.4 Fuel system. It is also recommended to carry out the checks described in the relevant paragraph (3.9 Final checks) before starting the engine.

3.1 Preparing for installation

On delivery of the engine:

- Check that the six-digit serial number on the engine casing matches the number on the packaging box.

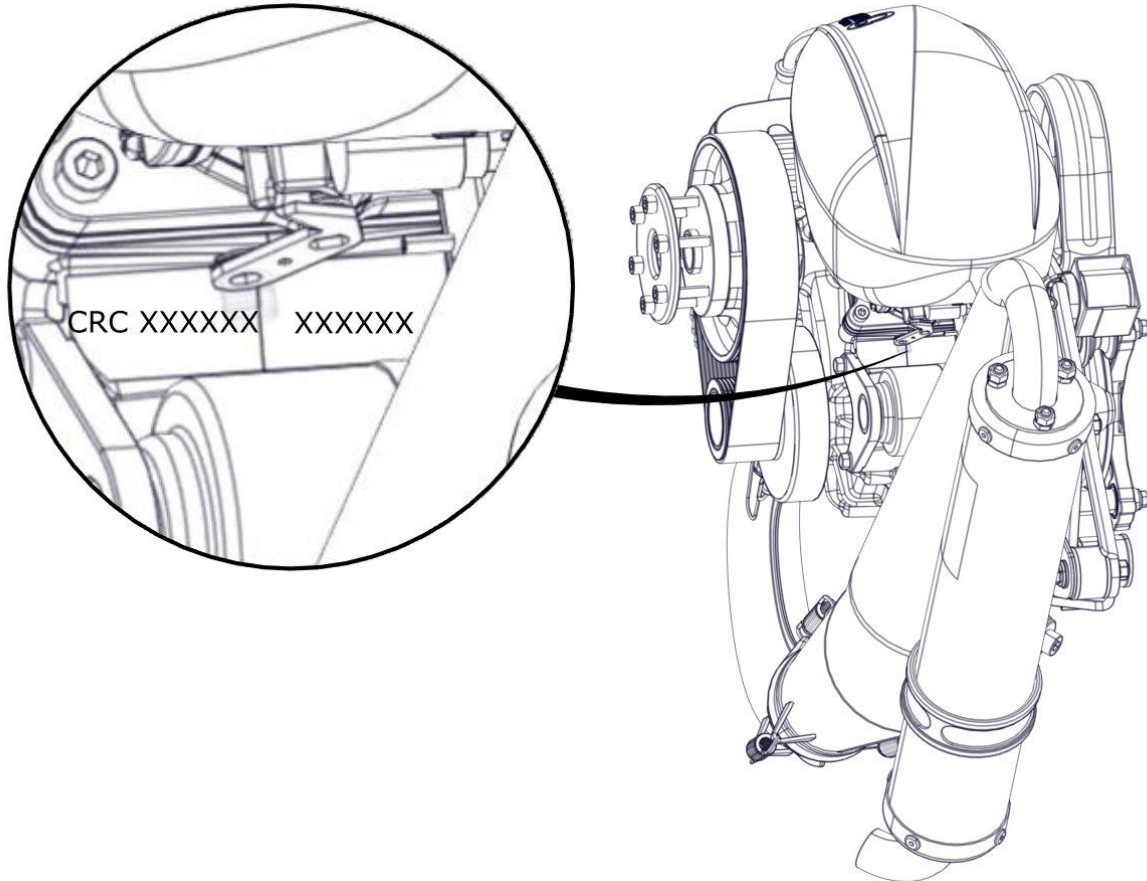

Check that there is no damage of any kind related to the transport of the engine.



Engine openings are closed by special plugs to prevent the entry of foreign substances and moisture. These should only be removed when necessary, for installation.

Moster 185 Plus MY19 (Dual starter in the illustration)

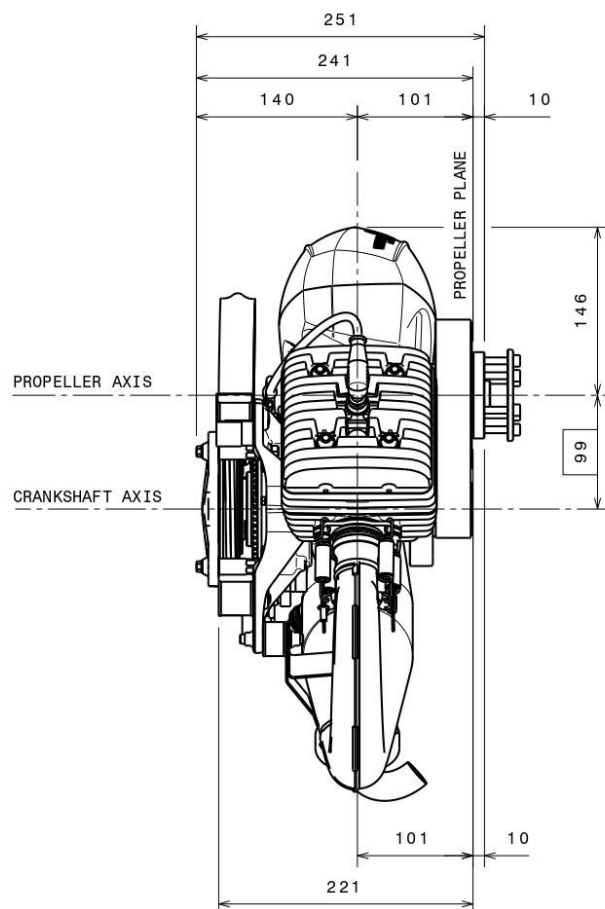
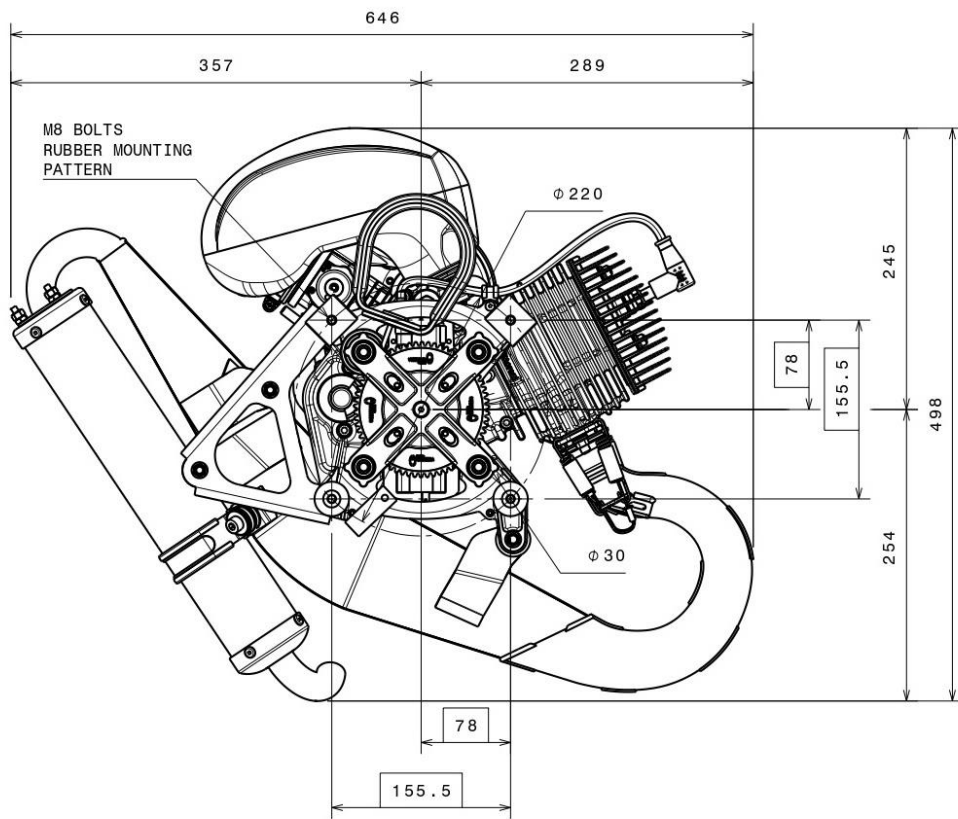

PROPELLER MOUNTING

PROPELLER
ROTATION

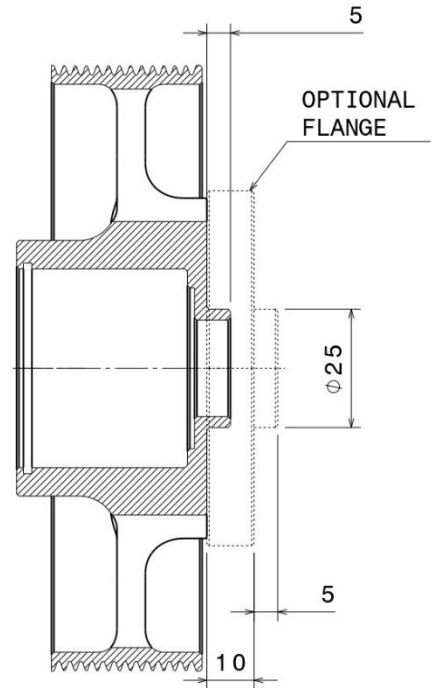
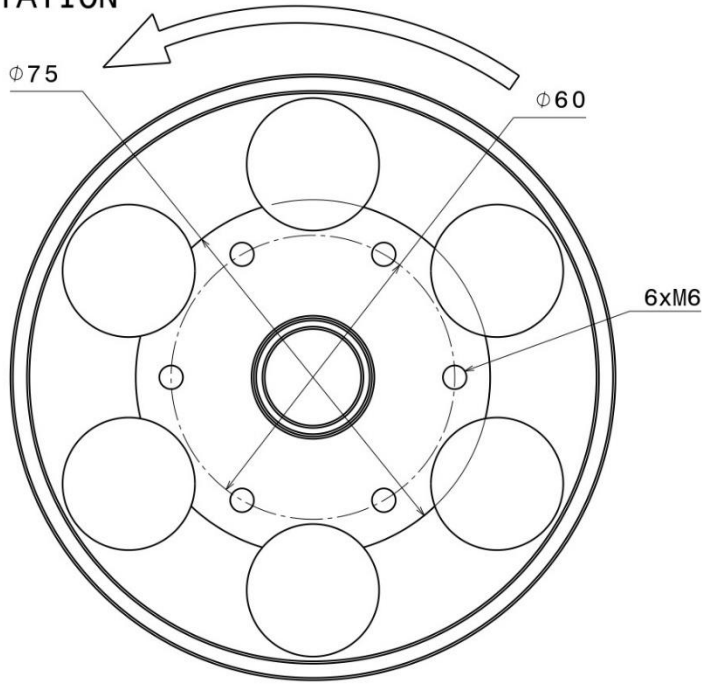

PROPELLER ROTATION

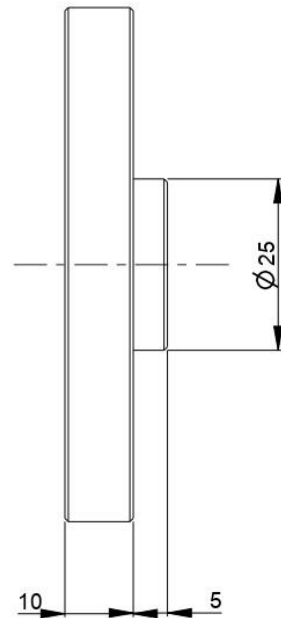
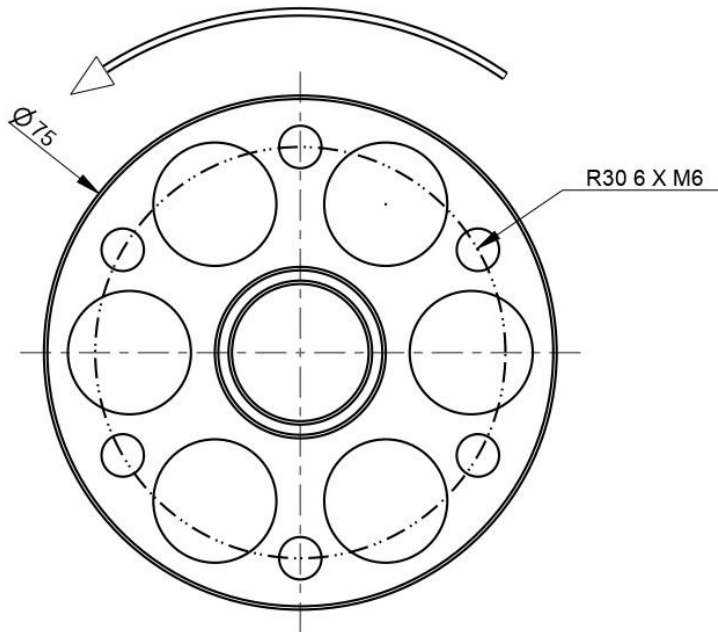

Moster 185 Plus MY20/MY22 (Dual starter in the illustration)

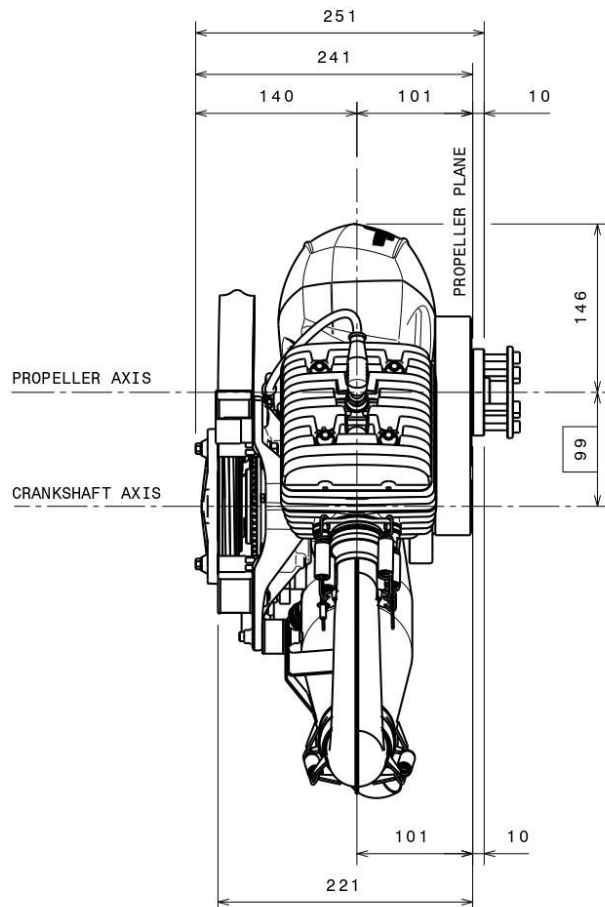
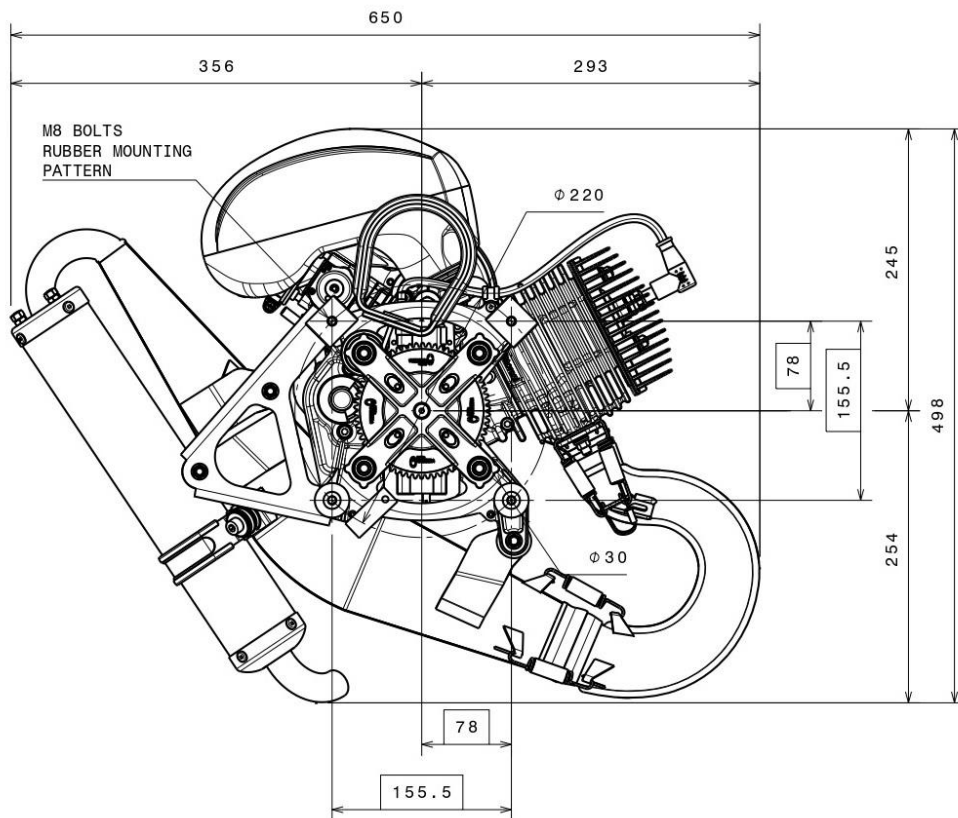

PROPELLER MOUNTING

PROPELLER
ROTATION

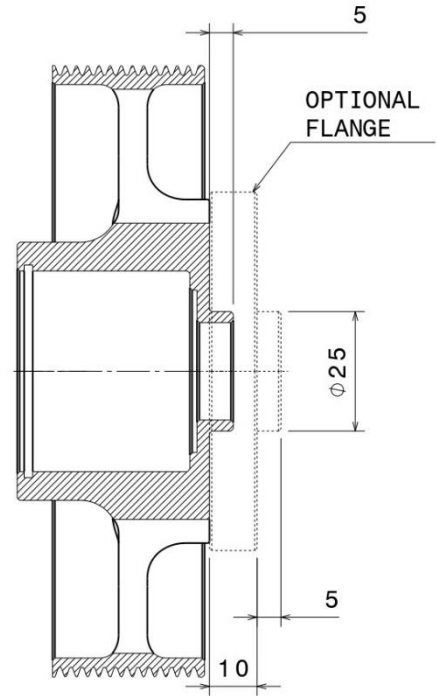
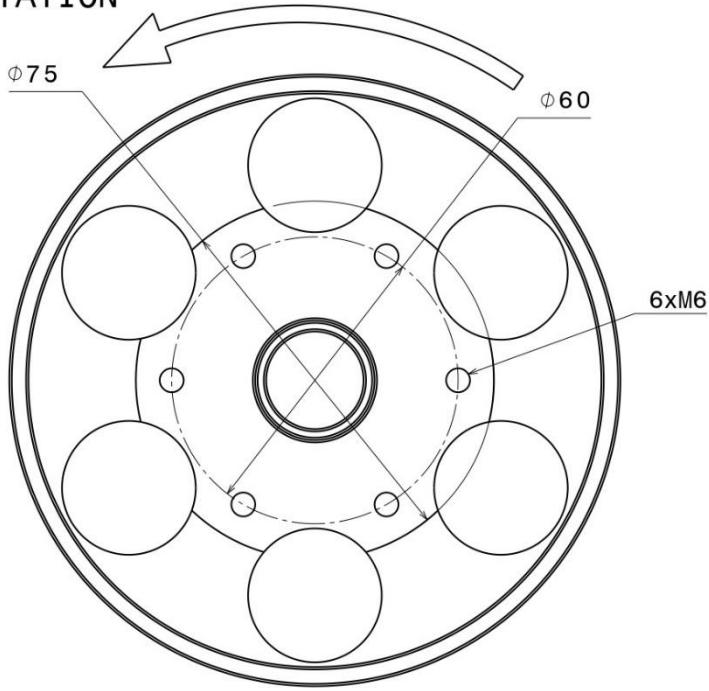

PROPELLER ROTATION

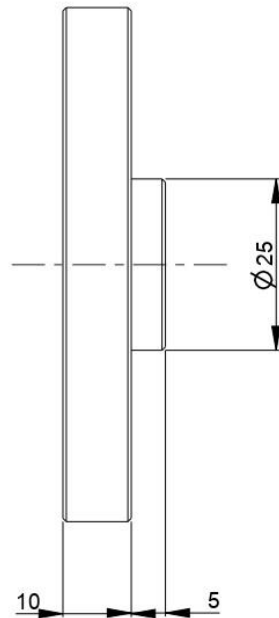
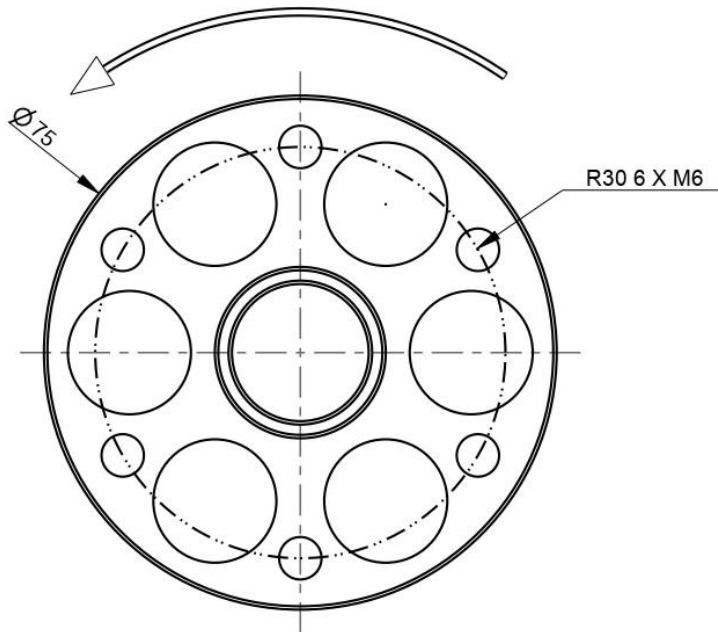

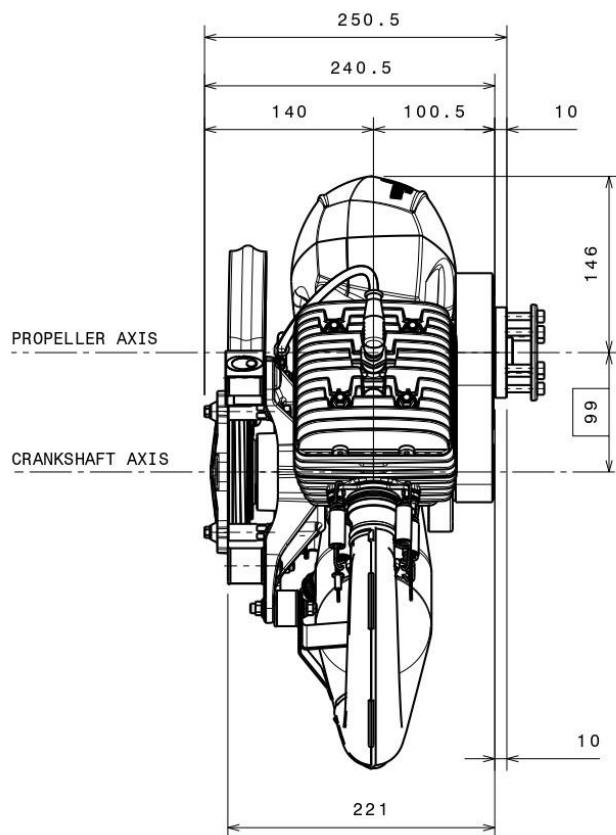
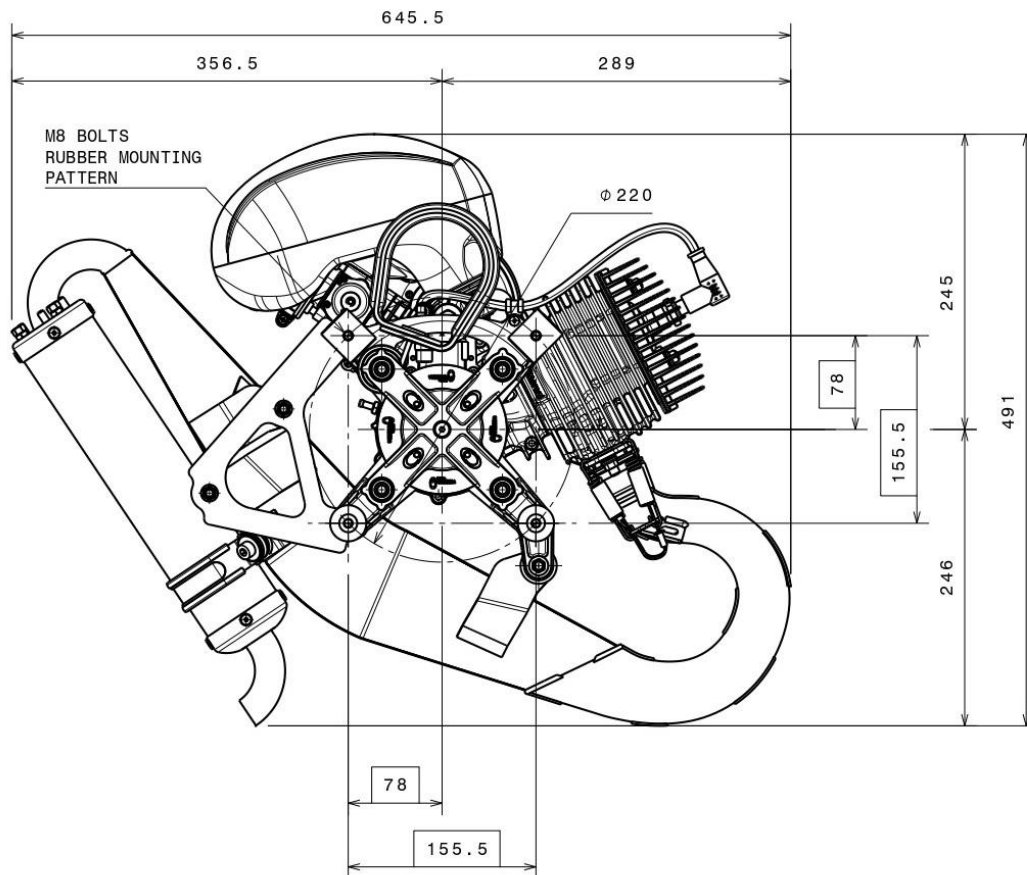

PROPELLER MOUNTING

PROPELLER
ROTATION

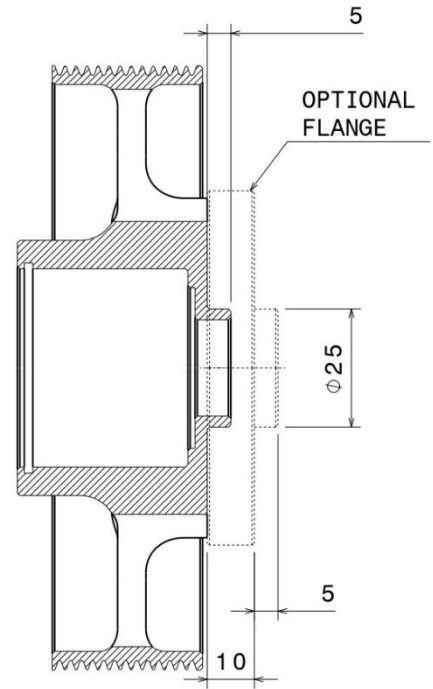
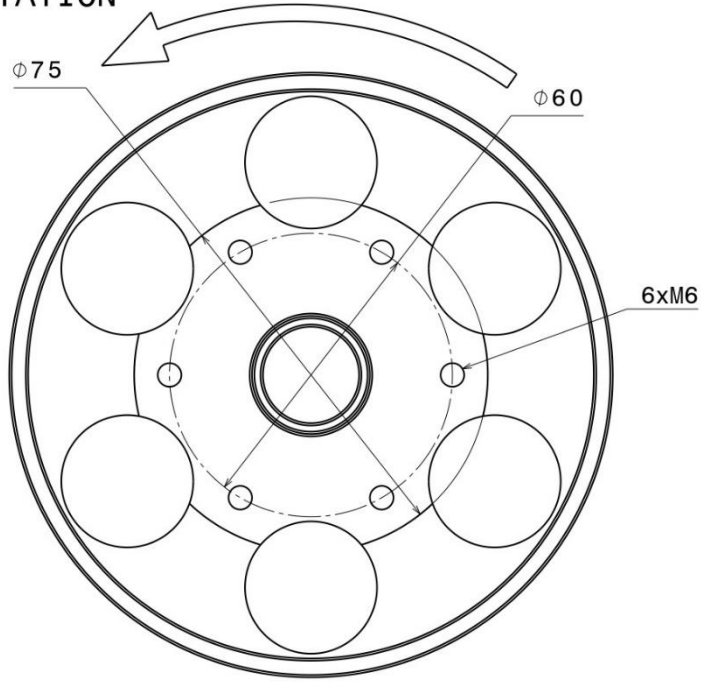

PROPELLER
ROTATION

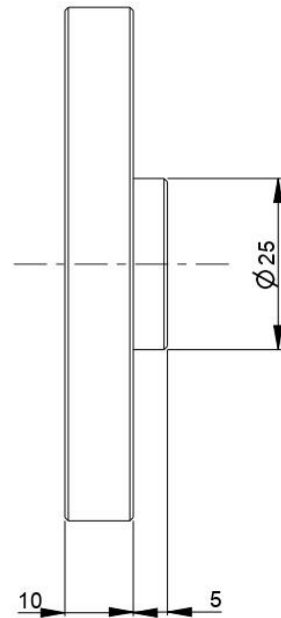
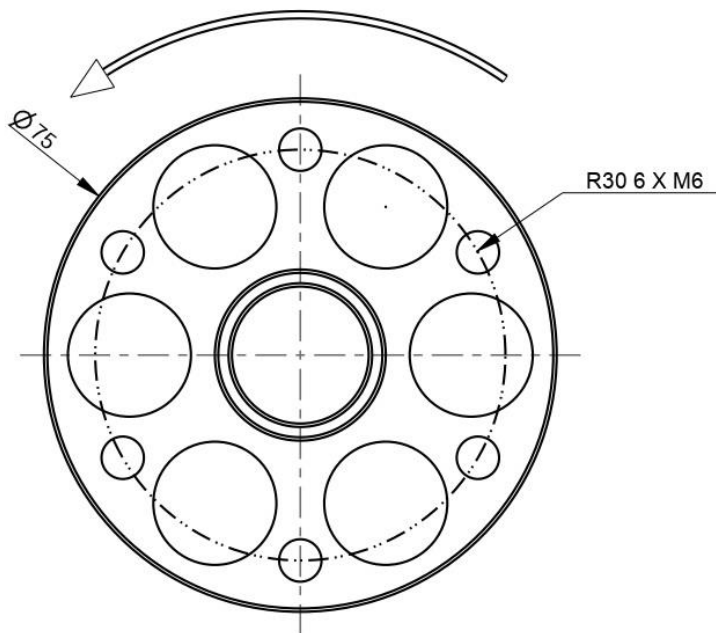

3.2 Supports to the frame

The engine is fixed to the aircraft frame through the 4 dampers. Do not replace the dampers, as they are designed and approved for this engine. Use M8 screws for fixing, taking care not to rotate and damage the rubber part. The vibration dampers reduce the vibrations transmitted from the engine to the frame. For safety reasons, straps are fitted around the vibration dampers.

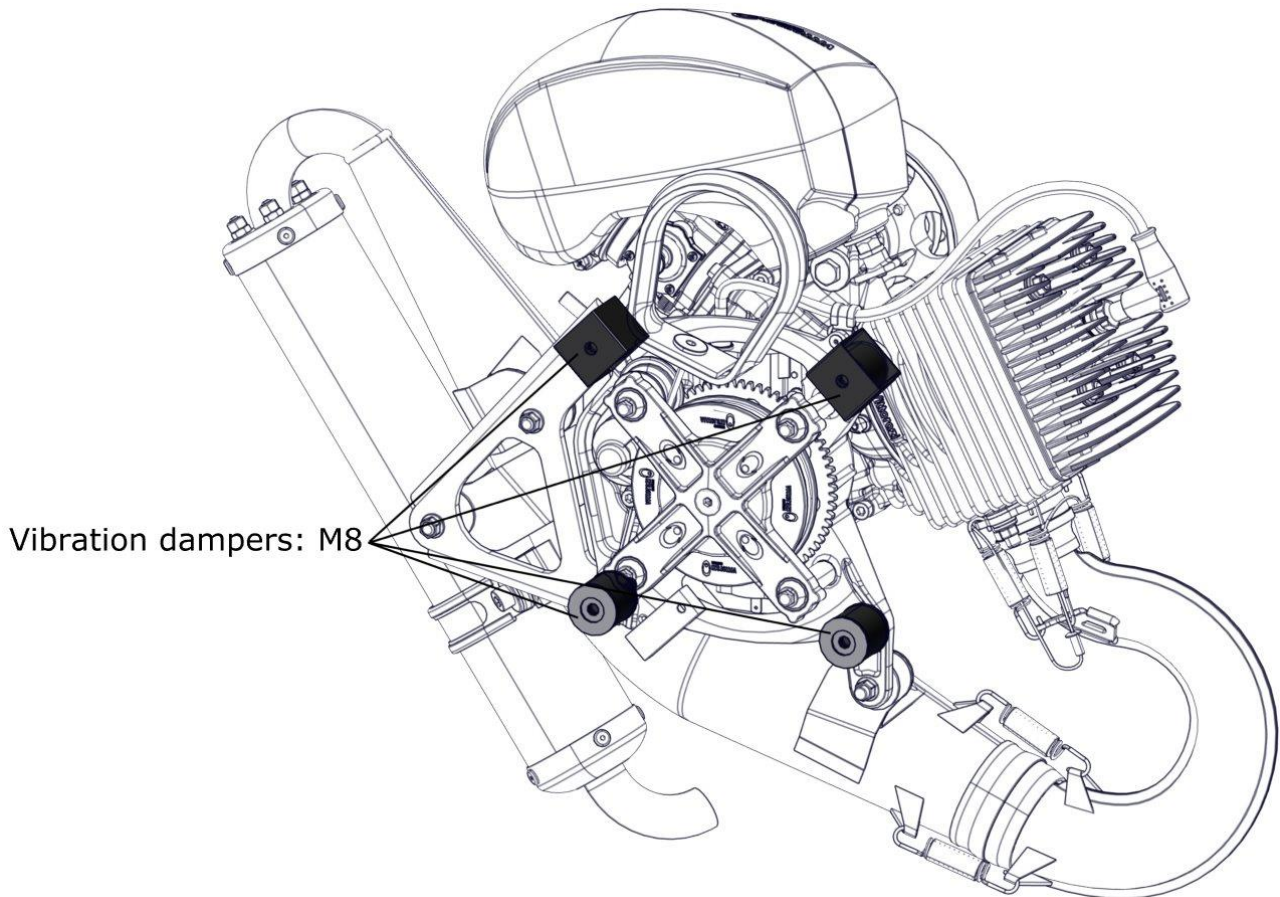

The components to be installed, in particular the fuel tank and fuel hoses, must have a certain distance from the exhaust system as high temperatures are reached during engine operation.

3.3 Electrical system

The illustration below shows the position of the electrical components installed on the engine in the Dual starter version.

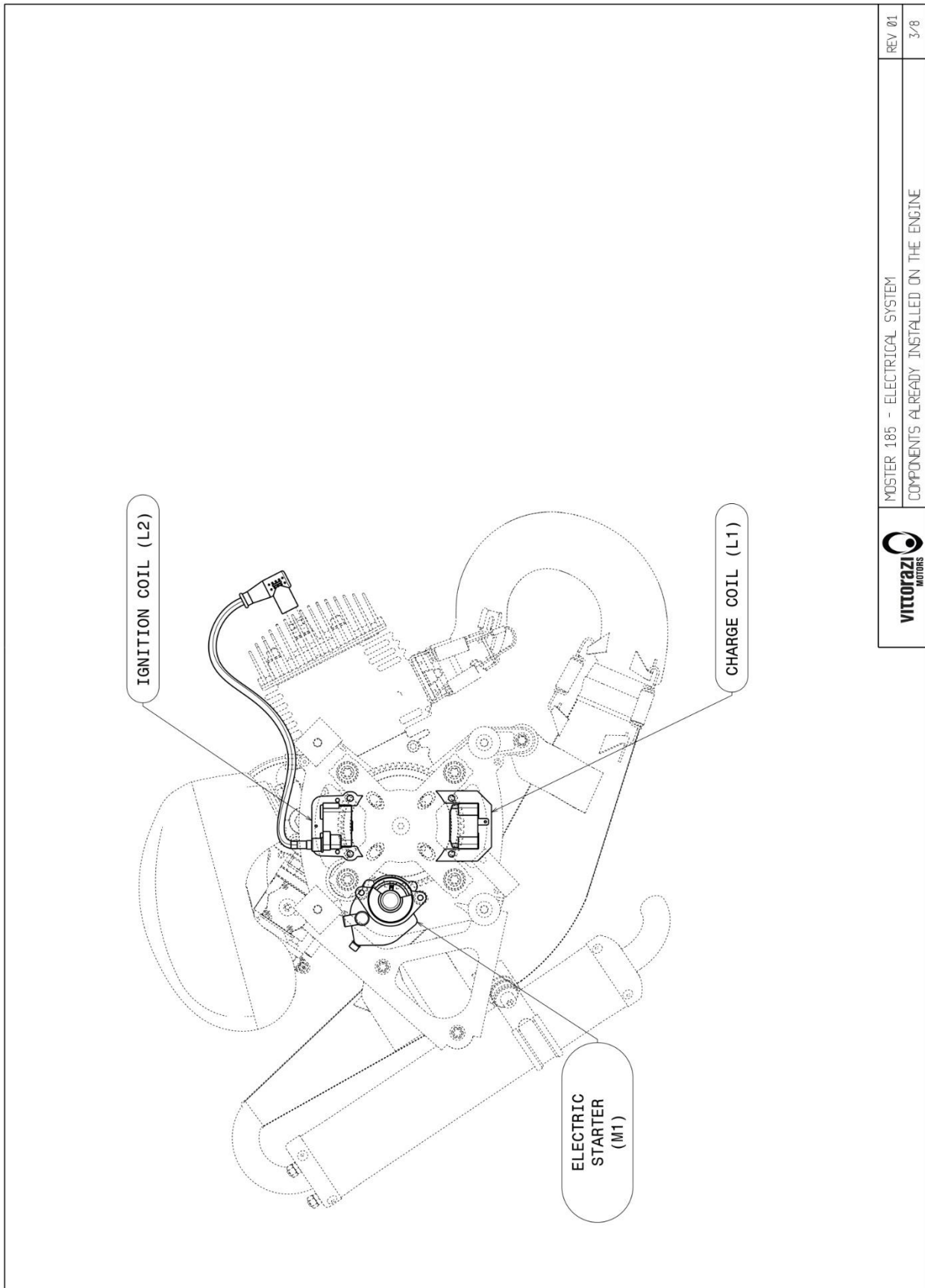

Circuit diagram, Manual starter

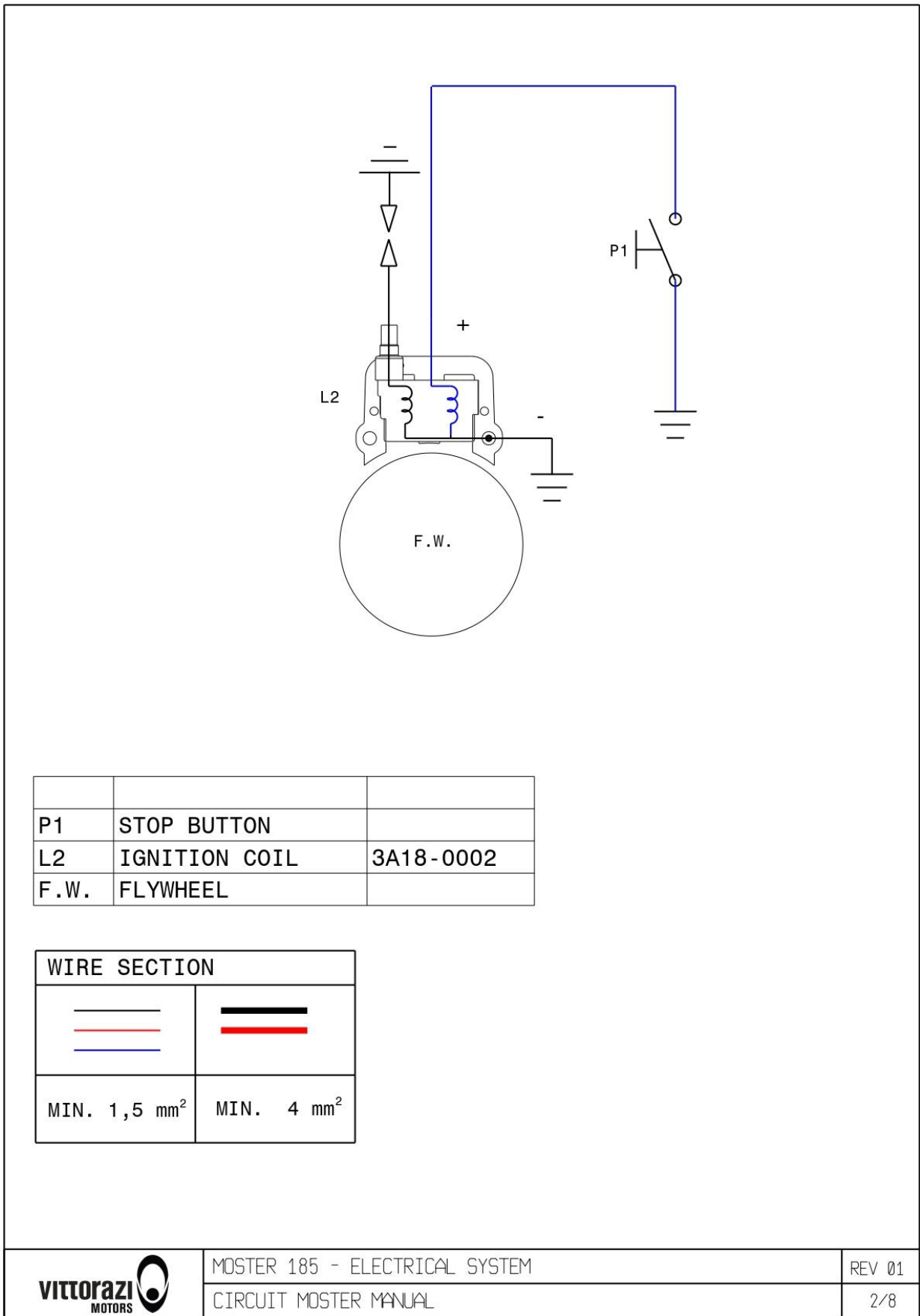

Ignition coil.

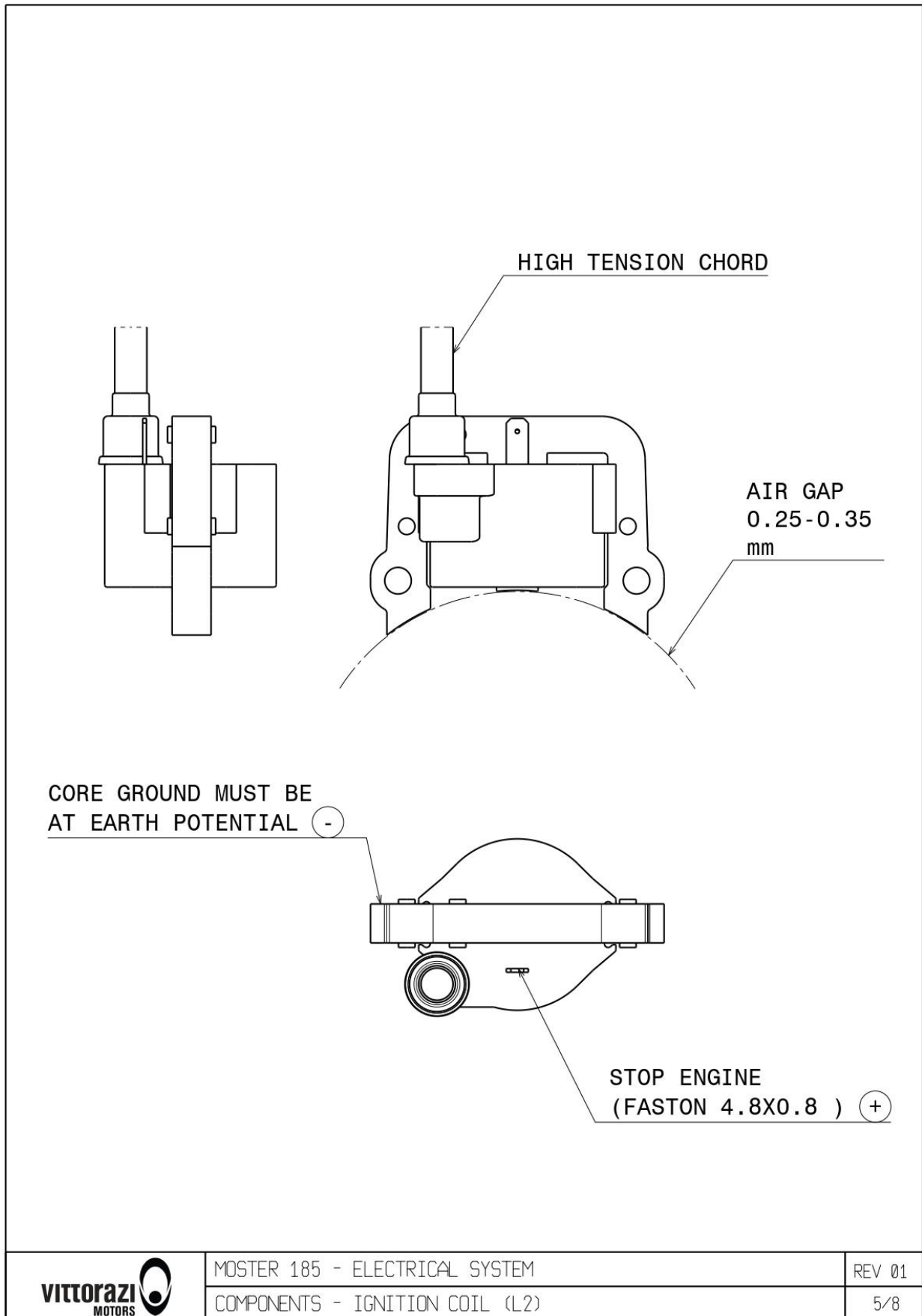

Charge coil.

AIR GAP
0.3 - 0.5

6

+B

0.5

S N

0 DIRECTION OF ROTATION

0.8

10

ACTUAL CIRCUIT

+B

12V BATT.
Min. 2Ah

-B

482047

I out @ Vout = 12.5Vdc CONST

I out [mA]

[x 10³ r.p.m.]

RESISTANCE VALUE OF COILS (AT 20° C)	
MEASURING PLACE	RESISTANCE VALUE (OHM)
FASTON-CORE	1.0 ± 10%

NB. TEMPERATURE MUST NOT EXCEED 70° C ON CORE, NEAR HOLES FOR FIXING IGNITION TO CRANKCASE, SIDE CRANKCASE.

-B

vittorazi
MOTORS

MOSTER 185 - ELECTRICAL SYSTEM

COMPONENTS - CHARGE COIL (L1)

REV 01

6/8

Electric starter.

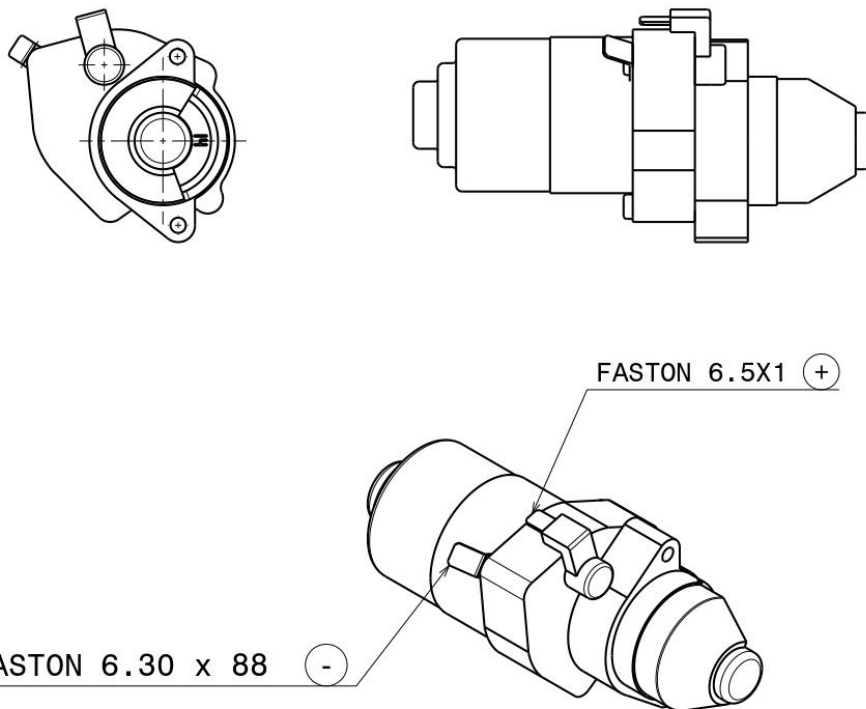

INPUT	12 V
POWER	0.3 kW

	MOSTER 185 - ELECTRICAL SYSTEM	REV 01
	COMPONENTS ALREADY - ELECTRIC STARTER (M1)	4/8

Voltage regulator.

CONNECTIONS, WIRES & TERMINALS			
POS.	TO BE CONNECTED TO	WIRE COLOUR	TERMINAL
A	+ BATTERY	RED	FEMALE CILINDRICAL $\varnothing 4$ WITH COVER
B	MALE TERMINAL ON COIL	BLUE	6.3 FEMALE WITH COVER
C	- BATTERY / GROUND	BLACK	$\varnothing 6.3$ RING

ACTUAL CIRCUIT

NOTE

- 1.1 LIMITED VOLTAGE: 13.5÷14.5VDC
- 1.2 REGULATOR MUST BE DISCONNECTED BY BATTERY WHWN ENGINE STOPPED.
- 1.3 WHEN REVERSED CONNECTED TO BATTERY, REGULATOR WILL FAIL
- 1.4 WHEN REGULATOR USED WITHOUT BATTERY IT WILL FAIL
- 1.5 UNIT TEMPERATURE WORKING RANGE: -10° C TO 50° C (ON UNIT SURFACE)



MOSTER 185 - ELECTRICAL SYSTEM
COMPONENTS - VOLTAGE REGULATOR (RT1)

REV 01
7/8

Spark plug:

Screw the spark plug into the head and tighten to 25 Nm.

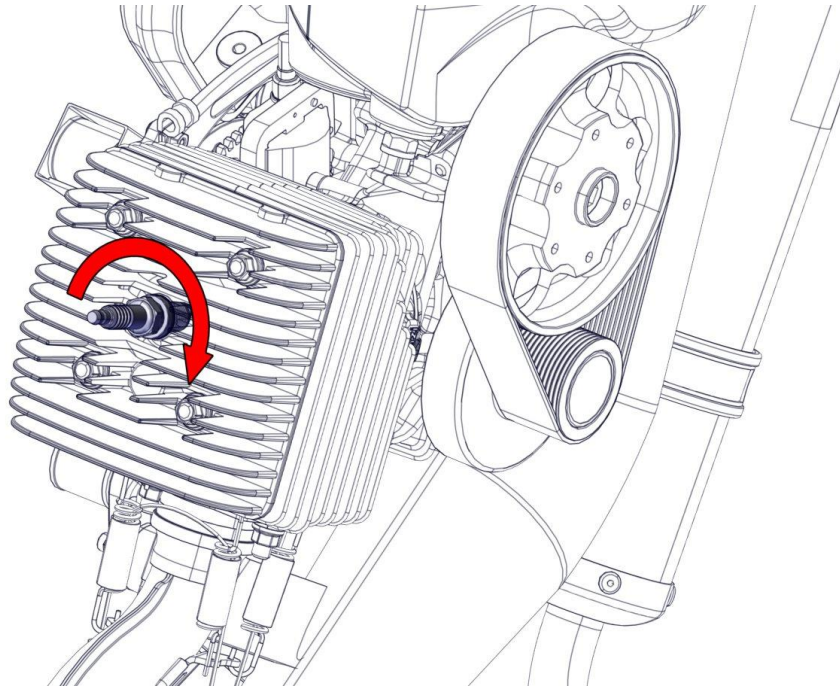

Fully insert the spark plug cap into the spark plug and check that the connection is secure.

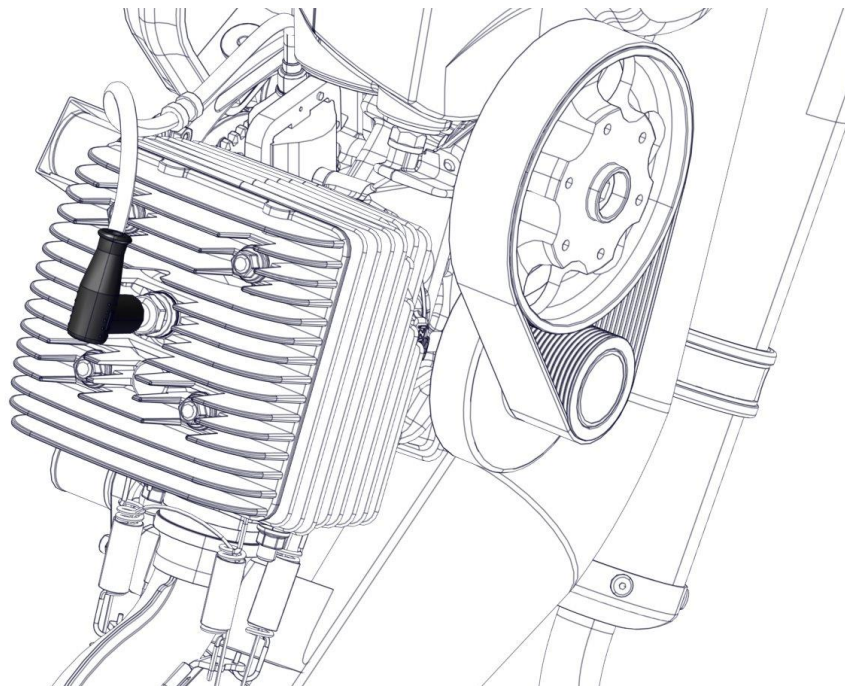



Installation warnings.

- Voltage regulator must have sufficient air cooling: check its position carefully.
- When voltage regulator is used without battery it will fail: connections to battery must be solid, use quality battery.
- When voltage regulator is reverse connected to battery, it will fail.
- The minimum cross-section of the cables that connect the battery to the starter motor must be of 4 mms² and their length must never exceed 500 mms.



Installation advice.

Place the start button in a position where it is not possible to be pressed accidentally:

- Accidental start of the engine can be a risk for the user and can lead to severe injury.
- Whenever this happens while the engine is revving higher than idle the electric starter may be damaged.

Check that voltage regulator works within regulations limits after installation.

Battery:



Use a 12 V, 2,5 Ah (min.) lead acid battery only with an inrush current of 150 CCA.



Disconnect battery from the electrical system before recharging: always use a battery charger suitable for the chosen battery to avoid any risk of explosion due to improper charging.

3.4 Fuel system



This engine model uses a diaphragm carburettor. The position of the tank and the configuration of the fuel line affect the operation of the carburettor and the engine. Vittorazi has performed many validation tests to identify the right configuration and its limits.



The fuel tank must be positioned properly. The level of the tank bottom must remain at a maximum distance of 70 cms from the carburettor. Larger distance can compromise the carburettor pumping, up to reduce the fuel flow rate, thus leaning the carburation and potentially overheating the engine. By placing the tank in the gap between the indicated maximum distance (70 cms) and zero, it leads to negligible changes in flow rate. In the event that this value is not respected for special aircraft geometries, contact Vittorazi directly.

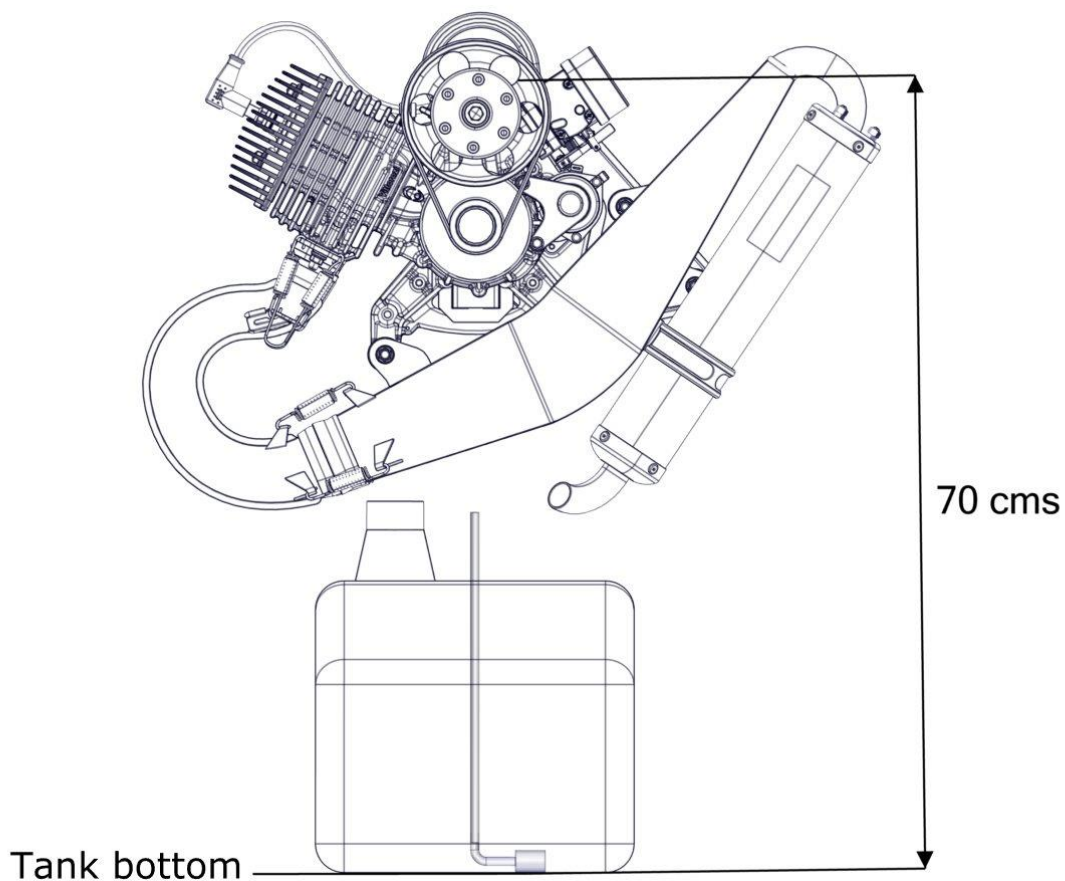



The connection from the tank to the carburettor must be made with a single direct hose, as short as possible. Do not install primer bulbs or other devices as they may cause a pressure drop and possible air to be sucked into the fuel system. Use suitable hoses that are resistant to fuel mixture.

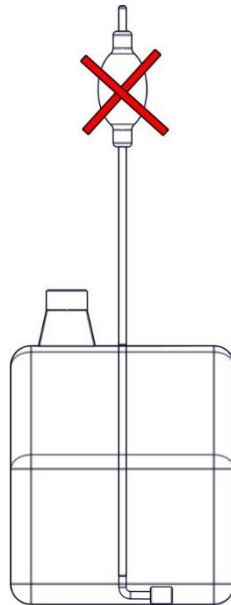

The entire fuel line (from the catching filter in the tank to the carburettor inlet) must be airtight. Entry of air into the line can cause instability at idle, up to irregular behaviour in steady regime or acceleration.



Use a transparent tube to connect the tank to the carburettor. Secure all joints from the tank to the carburettor inlet with safety straps so that each connection is strong and prevent unwanted movement.

This will allow:

- When the engine is started, to see fuel entering the carburettor.
- With the engine running, to notice possible bubbles due to the aspiration of air from the connections of the piping or from the carburettor. In this case, carefully check the pipe connections and the carburettor.

For safety reasons, the engine has a suitable and resistant fuel mixture hose (length 65 cms) already connected to the carburettor inlet and secured with a double wire hose clamp. After mounting the petrol tank with internal filter (compulsory), connect the hose to the tank.

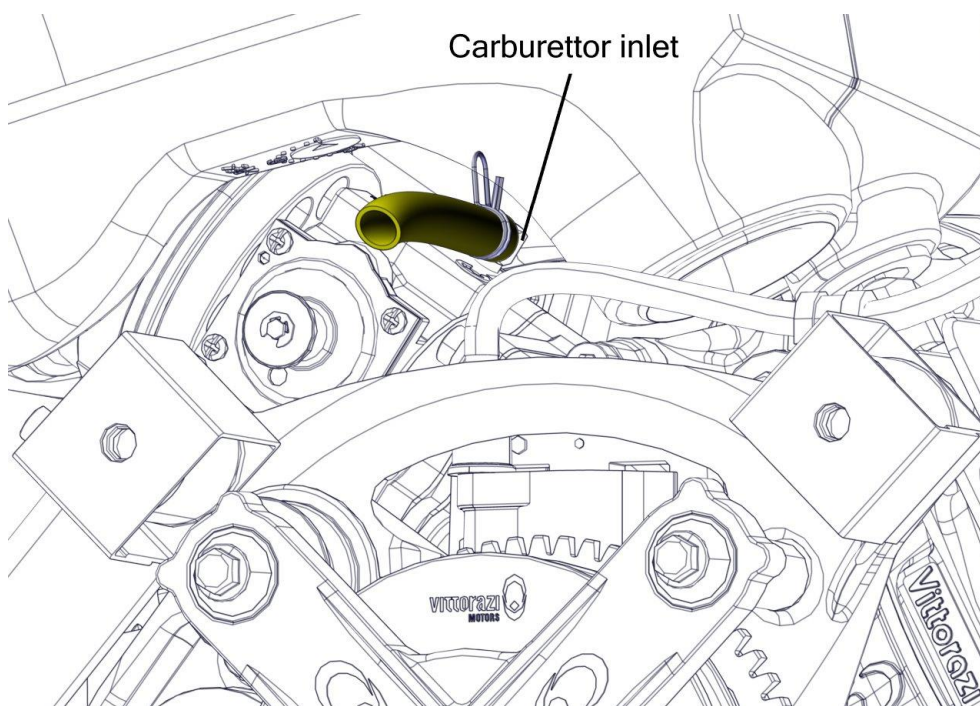

For safety reasons, the engine has the airbox already fitted, which can be removed if necessary, during installation. When reinstalling it, check that the airbox has been fitted correctly, and in particular that the fixing clamp (1) on the sleeve and the safety strap (2) have been securely fastened.

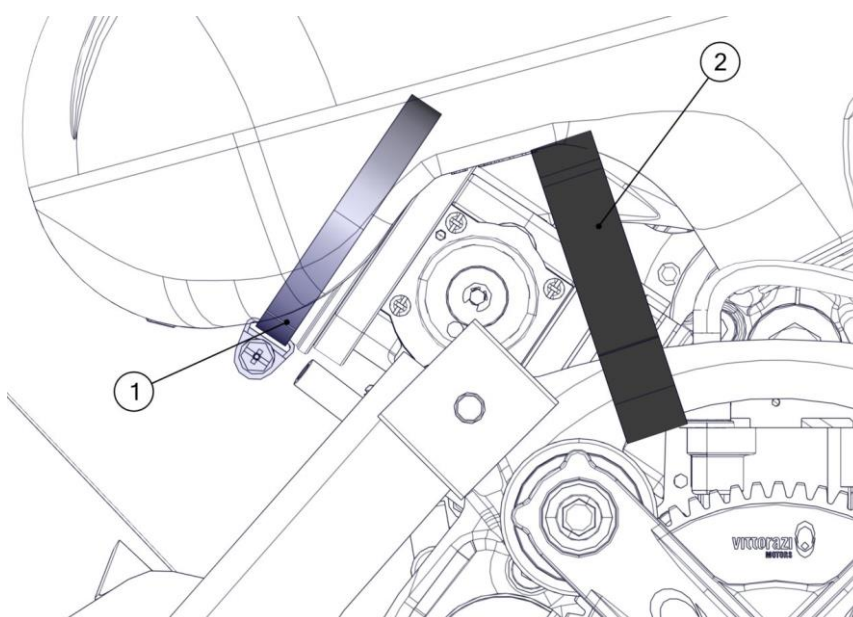

3.5 Bowden carburettor cable

The Bowden cable for throttle control has to be connected to the carburettor. Screw the accelerator Bowden cable inside the elbow shown in the figure.

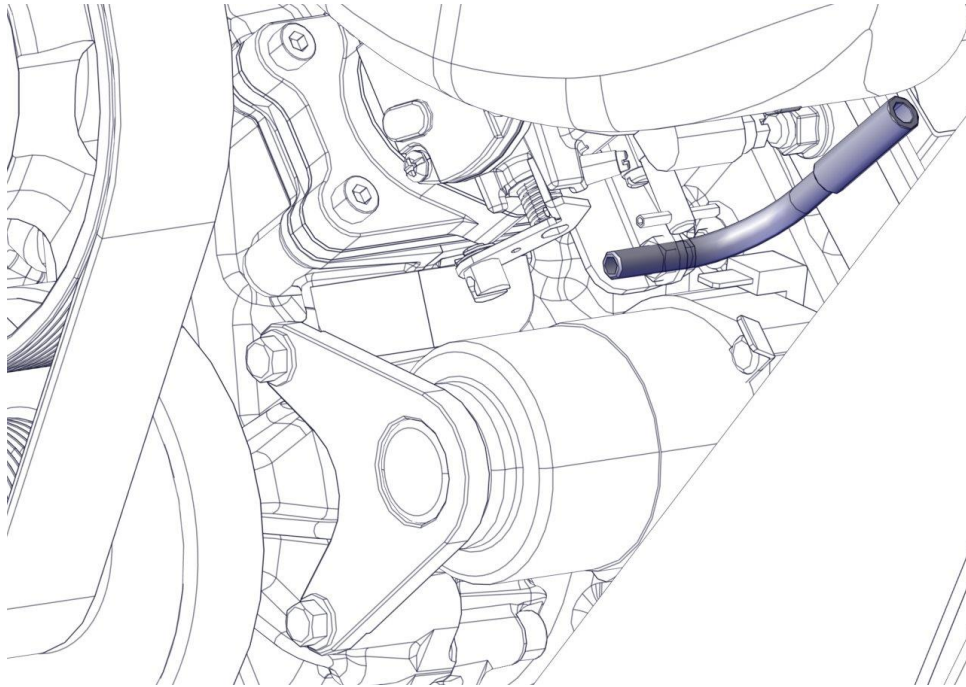

Then proceed to fasten the cable coming out of the elbow to the carburettor. The connection point is shown in the figure.



Secure the cable using 2 nipples to prevent loosening.

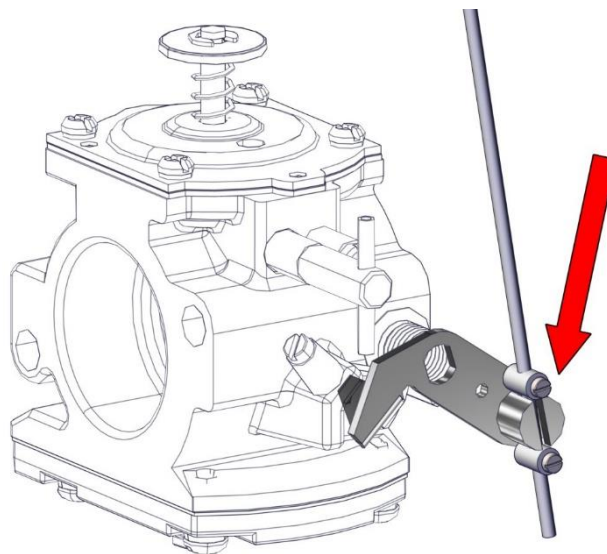



Check carefully:

- the Bowden cable is secured in the screw nipple;
- the full opening of the shutter;
- the sliding of the system;
- the return to the stop position each time the throttle is released.

3.6 Manual starter

Use a nautical-type pulley to support the manual starter rope.

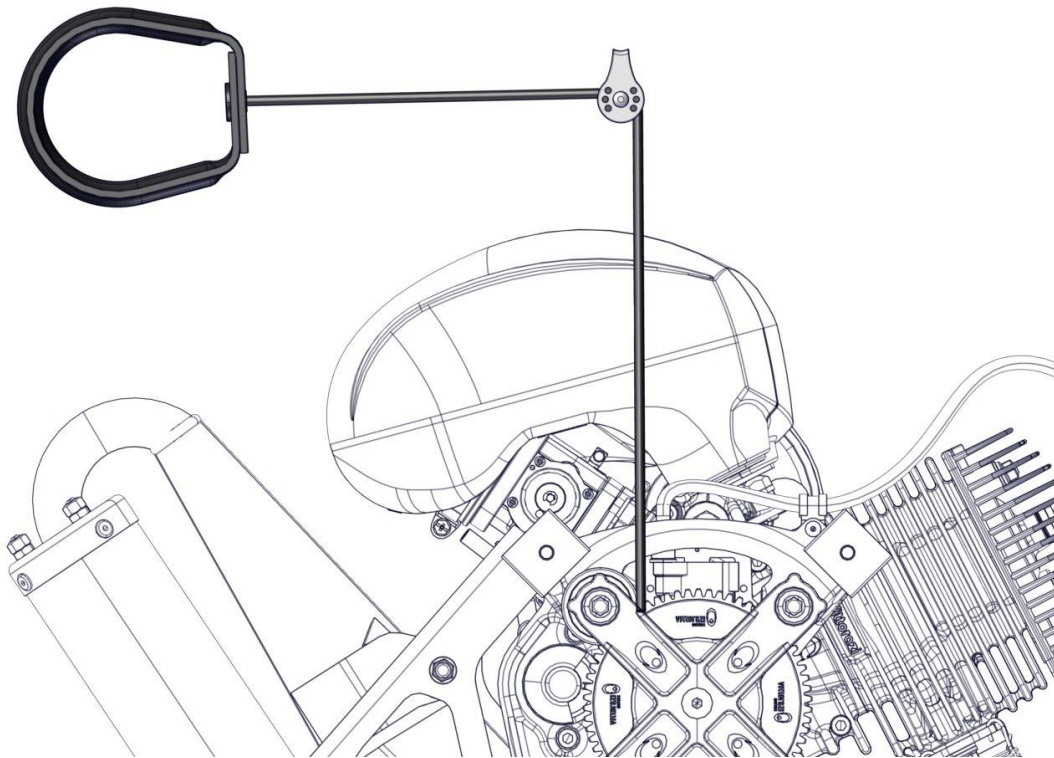

Depending on the installation's choice, the manual starter can be rotated in 3 different positions (every 90 degrees) to allow for a different position of the handle.

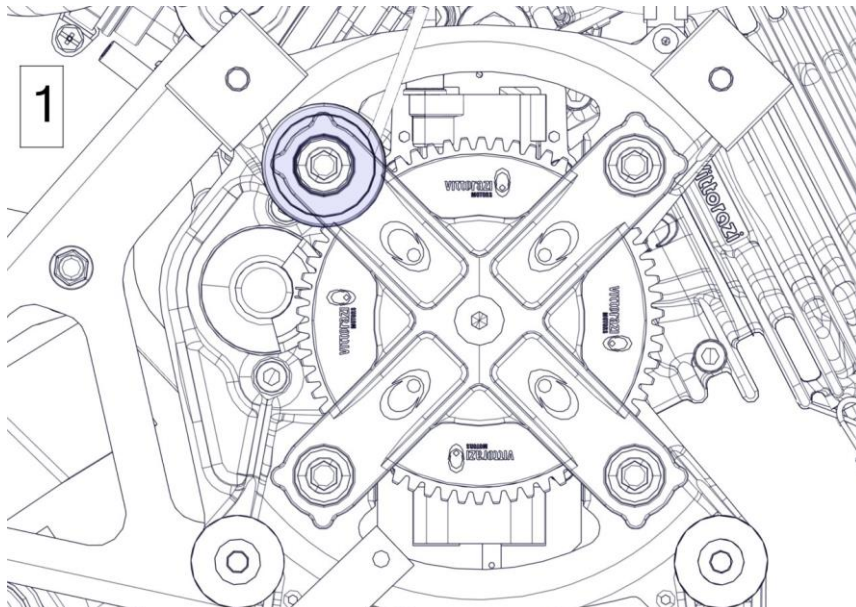



Check that the white mark on the rope comes out of the pulley on the starter support. This ensures the correct tension of the starter recoil spring as well as an adequate amount of rope wound in the system. According to the final position, secure the handle with a knot and trim the excess rope at the end.

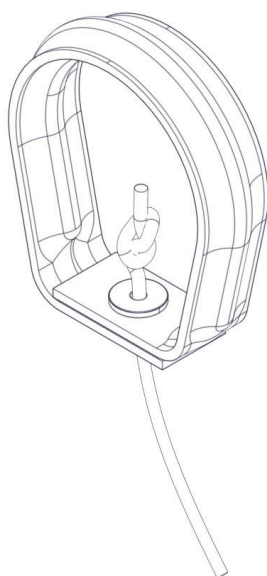
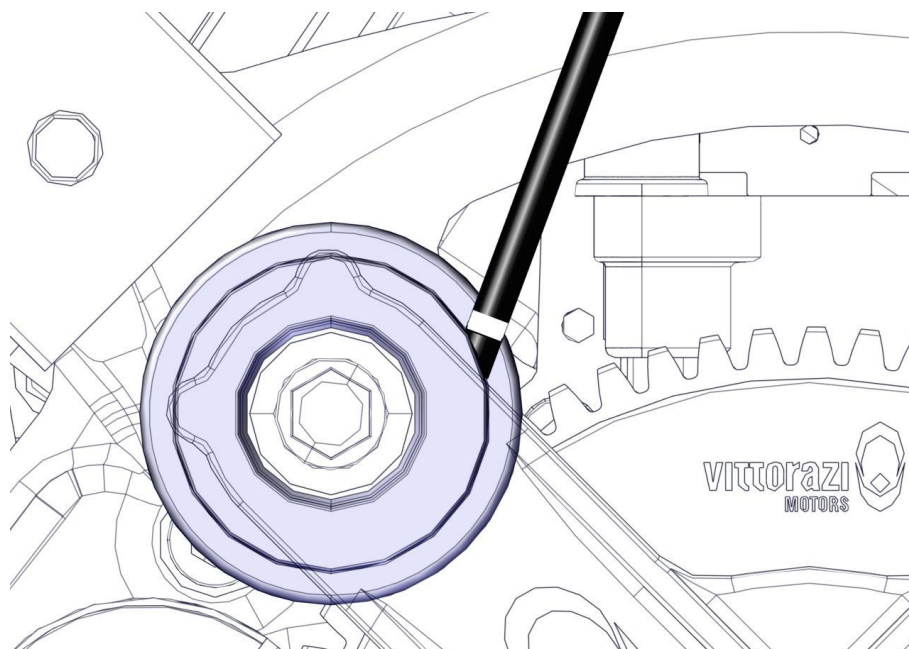

3.7 Propeller

Refer chapter 4.1 “Propeller assembling” in the User manual.

3.8 Instruments and accessories

The following accessories provide important information on engine operation: the tachometer, the CHT sensor and the EGT sensor. The tachometer is very useful for checking the state of the engine: idle, average and maximum speed are checked by comparing engine specifications.

The CHT (Cylinder Head Temperature) sensor is useful for monitoring temperatures in flight. The CHT sensor fits on the engine head under the spark plug and it's the most recommended for simplicity.

The EGT sensor makes it possible to monitor the temperature of the exhaust gases and thus obtain information on the correct combustion of the engine. The installation of EGT sensor is more complicated than the CHT sensor, it requires a hole along the exhaust manifold, a critical area of each two-stroke engine. Recommended for experts or those who make competitions.



Installation of the EGT sensor voids the exhaust manifold warranty.



Refer to chapter 2 for engine limits to be respected (RPM, CHT, EGT).

3.9 Final checks

Once all components have been installed, the following checks should be carried out:

- All screws tightening applied during the installation process.
- Correct operation of the throttle.
- Pipe connections and no fluid leaks.
- All the electric connections safely wired.
- Correct ignition of the engine by the electric start or by the manual starter.
- Correct operation of engine instruments (tachometer, temperature sensors).
- Engine stop by killing switch.

Upon completion of the work, a ground test and then additional flight approval is required to ensure proper operation of the system. For each new model aircraft, a series of test must be performed and documented in appropriate reports after the initial engine installation. The company Vittorazi strongly recommends sending those reports that contain operating data (RPM, temperatures, consumption, etc) for validation.

