

Globe*light*

user manual

CAUTION!

Read the manual before using the equipment

INDEX

Page

1. Purpose.....	3
2. Technical data.....	4
3. Attached documents.....	4
4. Inspections and repacking.....	5
5. Repairs.....	5
6. Storage and maintenance.....	5
7. Design.....	6
8. Packing.....	7
9. Placing in the container.....	13
10. Connecting the V-risers	16
11. Fixing the Globe on the side of the harness.....	17
12. Fixing the Globe on the front of the harness.....	18
13. Example of a rescue throw.....	19
14. Placing the parachute in a harness-integrated container.....	20
15. Everyday inspection.....	20
16. Test results.....	20

Rescue Parachute User Manual

1. Purpose

Our GLOBE parachute is designed for solo flying and tandem paraglider pilots. In case of serious paraglider malfunction rendering further flight impossible, our system reduces the sink rate and allows for safe landing.

As standard, the system comes packed in its inner bag, ready to be inserted into harness-integrated container. Your harness should be equipped with its own release handle and V- or H-shaped risers, leading from the shoulder straps to the container. If any of these are missing, contact your harness dealer and/or manufacturer, since length and shape of those parts can vary with harness model and must exactly fit the one you are using.

As an option, you can get at Dudek Paragliders the externally mounted container, its release handle and V-risers. It can be attached to the front or side of the harness, depending on your preferences and harness characteristics.

Rescue parachute is activated manually by releasing the handle, pulling the bag out of the container and throwing it out along the direction of the airflow (together with the handle).

2. Technical Data

WARNING:

Will not withstand use at speeds exceeding 32 m/s (115 km/h)

GLOBE Light

Rozmiar:	90	110	135	Bi
Canopy System	1	1	1	1
Number of panels / lines	13	14	16	20
Surface flat [m ²]	22,50	26,30	32,50	55,90
Maximum opening speed [km/h]	115	115	115	115
Maximum opening time [s]	< 5	< 5	< 5	< 5
Maximum sink rate [m/s]	< 5,5	< 5,5	< 5,5	< 5,5
Maximum load [kg]	90	110	135	210
Weight [kg]	1,40	1,55	1,85	2,80

3. Attached documents:

- parachute card
- user manual

4. Inspections and repacking

IP parachute **must be aired and repacked every 12 months, and inspected every 24 months**. It should be done by the manufacturer or authorised paragliding riggers.

5. Repairs

Any repairs are to be carried out exclusively by the manufacturer, or company authorized by the manufacturer.

6. Storage and maintenance

Rescue parachute should be stored in a dry place of room temperature, away from any chemicals.

If the parachute gets wet, it should be dried in a room temperature. In case of contact with salty water, rinse it thoroughly with sweet water before drying.

Dirt and stains are to be removed with a moistened rag.

During winter operation be alert and keep snow away from the parachute container.

7. The structure of the rescue system

The rescue system consists of following elements:

- canopy (gores, wedges, canopy brink, vent opening, vent brink)
- suspension lines
- central line
- connecting riser
- bag (keeps the system folded)

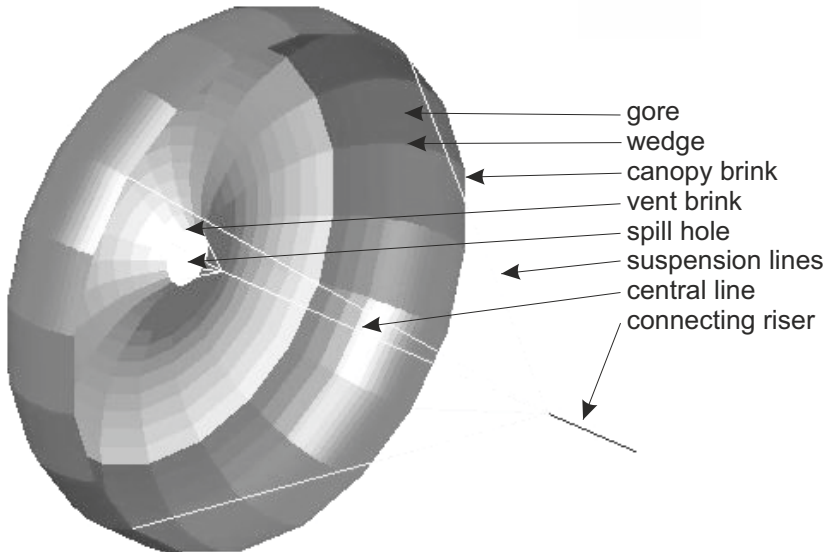

8. Packing the system

Before you start packing your parachute, it needs to be aired (that is - spread the canopy and straighten lines for 24 hours in a dry place of room temperature). Then carefully check the canopy gore by gore, as well as suspension lines and connecting riser for any damages.

The bag must be equipped with new elastic loops. Have more new loops at hand, to keep the chute suspension lines sorted.

Smooth and clean surface (a table would be best) of at least 7-10m x 1,0 m dimensions is required for packing the system.

Fix the connecting riser to the edge of table and spread the parachute flat.



Find the first outer suspension line and keeping it in hand go to a data sheet gore. Further along this line there are assistance straps sewn into top part of the canopy. Lead an assistance line through these loops and fix it to the other edge of the table.



Start packing from the data sheet gore.



Place the data sheet gore on the right side of the table. Grab the first two suspension lines together with central line and start flaking each wedge out with the other hand, adding subsequent lines to the bundle. Stop after flaking half of the total gores number.



Gores and wedges have to be pulled out completely and accurately. After completing right half of the canopy, cover it with the unsorted left half and start over again.



In the end check that no wedge was overlooked and there is the same number of wedges on each side. Sort the top part of the canopy. Size 90 is an exception here, since it has an uneven number of gores. Place the last one on the white side.



Drawing and pictures show correct organisation of the canopy brink and top (number of wedges on the picture was reduced for sake of clarity).

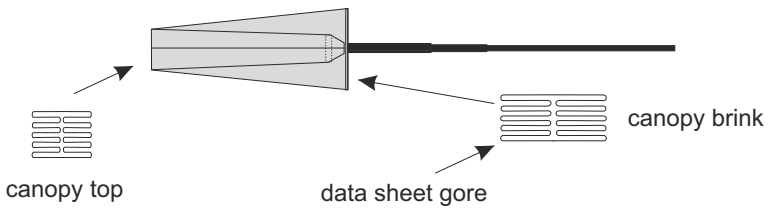

Check if the lines cleanly split into right and left halves and if the central lines (fixed in the middle of connector link) do not cross with suspension lines all the way to the spill-hole.

Stretch the lines after checking.





Fold the lower part of the canopy in a double "Z", and the top as a single "Z".



Remove the assistance line from canopy top.
Place the bag in the vicinity and start folding
canopy as shown, first vertically...



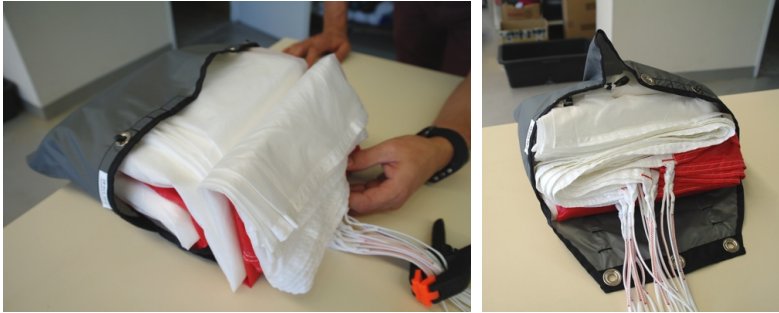

...then laterally. Slid the bag over folded canopy.
Fold the lines into three 'double eights' and put rubber loops over the ends.



Picture shows correct appearance of the double eights before placing them in the bag.

Lead the middle loop through nearest eyelet.





Place the three double loops in the bag. Close it with middle rubber loop, interlacing lines through it.

Lead the lines through other rubber loops, completely closing the bag.



Remaining lines (length about 40-70 cm) are to be fixed on top of the bag. If there are any rubber loops left unused, they should be detached from the bag.



After fixing the lines parachute is ready to be put into a harness-integrated or external container.

9. Placing parachute in the external container

Attach release handle to the bag by fixing its strap to one of the loops.

The connecting riser should be pointing sidewise, towards narrow flap of the container.



Place the bag in the container, lines down.

Lead assistance lines through loops and eyelets of the container.





Using assistance lines and pins close the container side lips. Close the lower lid then, replacing the assistance pin with those of the release handle. The last additional lip should be closed with the other pin of the handle.

Pull the assistance lines out, fix the handle with velcro and stick the ends of the handle into elastic pockets.



Connect the connecting riser with V-shaped risers, using direct knot or stainless steel quicklink (at least 6 mm rod diameter). Possible knot must be well tightened up, without possibility of sliding, while quicklink should be secured with rubber loops.



Excessive riser/risers are to be placed between the support and cover lid, and loose ends should be directed in accordance with harness' connecting options.

Design of the container allows for attaching it to all harness configurations without need of any changes in its closing scheme.

Close the cover lid by leading it through the release handle, firmly connecting the Velcros and putting the excess into corresponding pocket on the lower lid.

The last picture shows buckles attaching container to the harness and a pocket with parachute ID card.



10. Connecting the V-risers of the harness



11. Fixing the Globe on the side of the harness



12. Fixing the Globe on the front of the harness



13. Example of a rescue throw



14. Placing the parachute in a harness-integrated container.

Connect the connecting riser with harness risers.

Attach release handle to the bag.

Put the parachute in harness container. Close the container using release handle pin.

Make sure the pin is secured, so that it will not drop out on its own.

It is recommended to have the container pin sealed by an authorised rigger with a thread of max. 5 kg tenacity.

15. Everyday use inspection

Loops and pins closing the container require constant monitoring.

Before each start you should check if:

- the pins are not loose (can result in unexpected opening)
- no part is blocking the pins, thus making release impossible.

Parachute must be kept clean and dry at all times.

16. Test results

Test results showing compliance with EN 12491:2001 are available at the manufacturer.



Dudek Paragliders
ul. Centralna 2U
86-031 Osielsko, Poland
tel. + 48 52 324 17 40
info@dudek.eu

www.dudek.eu

made in europe